

KOHLER Diesel KDI

55 - 100 kW



KOHLER Engines

KDI 3404. UNIQUE, BUT NOT FOR A UNIQUE REASON.

THE LOWEST FUEL CONSUMPTION IN ITS CLASS

The new KDI 3404 offers fuel consumption more than 10% lower than competitors in its segment, with performance equivalent to that of larger displacement engines. All this is possible thanks to an advanced injection system (2000 bar Common Rail, electronically controlled EGR valve, four valves per cylinder), and no DPF.

GREATER PRODUCTIVITY

The new KDI 3404 offers the same performance as that of larger displacement engines thanks to the highest torque and specific power figures in its segment. The high torque at low rpms also allows machine productivity to be maximised and provides immediate response even at low engine speeds. The result is up to 15% greater productivity than other engines in the segment with the same level of emissions.

FLEXIBILITY OF APPLICATIONS

The new KDI 3404 has two side auxiliary power take offs positioned so as to provide maximum flexibility and allow compact installation for hydraulic pumps of many different displacements, in response to the increasing demand for hydraulic devices on industrial machinery.

COMPACT DESIGN

The new KDI 3404 does not use a DPF, and the result is the most compact engine in its category. This allows manufacturers to design machines with smaller engine compartments, aiding driver visibility and therefore increasing both safety and productivity.



INNOVATIONS



BENEFITS

RELIABILITY AND SAFETY

The new KDI 3404 has no limitations on its use. The lack of DPF reduces the engine size and means the work cycle is not interrupted by regeneration, thus increasing productivity. It also means expensive heat shielding is not required to protect against the fire risk caused by the high temperatures generated by DPF regeneration.

FUN TO DRIVE

The new KDI 3404 boasts an exceptional response to variations in load thanks to the turbocharger's perfect integration with the engine and the electronic performance management. The high levels of torque available at low rpms allow the engine to work effectively even in the most demanding conditions.

LONGER MAINTENANCE INTERVALS

The new KDI 3404 offers a minimum 500 hours oil change interval, thanks to its clean combustion which does not require a DPF. The special cylinder smoothing performed by next-generation machinery and the innovative design of the cylinder segments themselves reduce friction, optimising oil consumption.

BEST-IN-CLASS COMFORT

The new KDI 3404 is the benchmark engine in its category in terms of its low noise, lack of vibration and absence of visible exhaust smoke. The special crankcase-bedplate architecture and the counter-rotating shafts contained within them make the engine truly best in class in terms of vibration and noise.

TURBO COMMON RAIL ENGINES

STANDARD EQUIPMENT

- Intake manifold
- Exhaust manifold
- Horizontal exhaust flange
- Lateral oil fill provision
- 3.2 kW electric starter
- 90A alternator
- SAE 3 (11" ½)
- Cabin heating provision
- Engine mounted oil filter
- Fuel filter with water sensor
- Environmentally friendly oil filter
- ECU
- Oil sump capacity 15.6 L
- Diesel Oxidation Catalyst (DOC) <56kW
- Selective Catalyst Reduction (SCR) >56kW

ACCESSORIES ON DEMAND

- Radiators with integral charge air cooler
- Mounting feet
- Heavy Duty air cleaner
- Downward exhaust flange
- Hydraulic pump provision on 3rd and 4th PTO
- 120A alternator
- Counterbalance shafts



KDI 3404TCR

QUICK SPECIFICS

4 Turbo Common rail

CYLINDERS

3359 Displacement
cm³

74 | **55.4** @ 2200 rpm
HP | kW TIER 4 Final
STAGE IIIB

375 @ 1400 rpm
Nm



DATA

DIMENSIONS (mm)

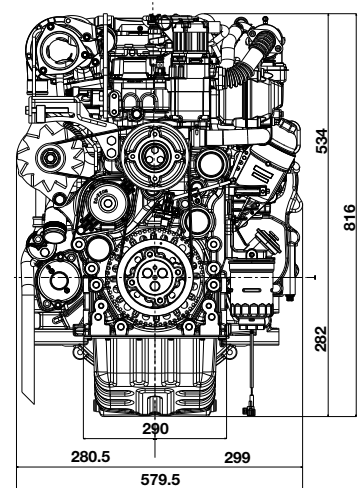
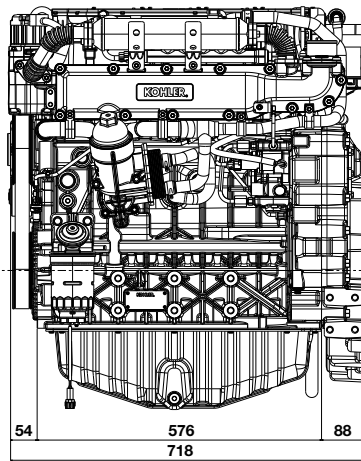

PERFORMANCE CURVES (IFN-ACCORDING TO ISO 3046 AND ISO 14396)

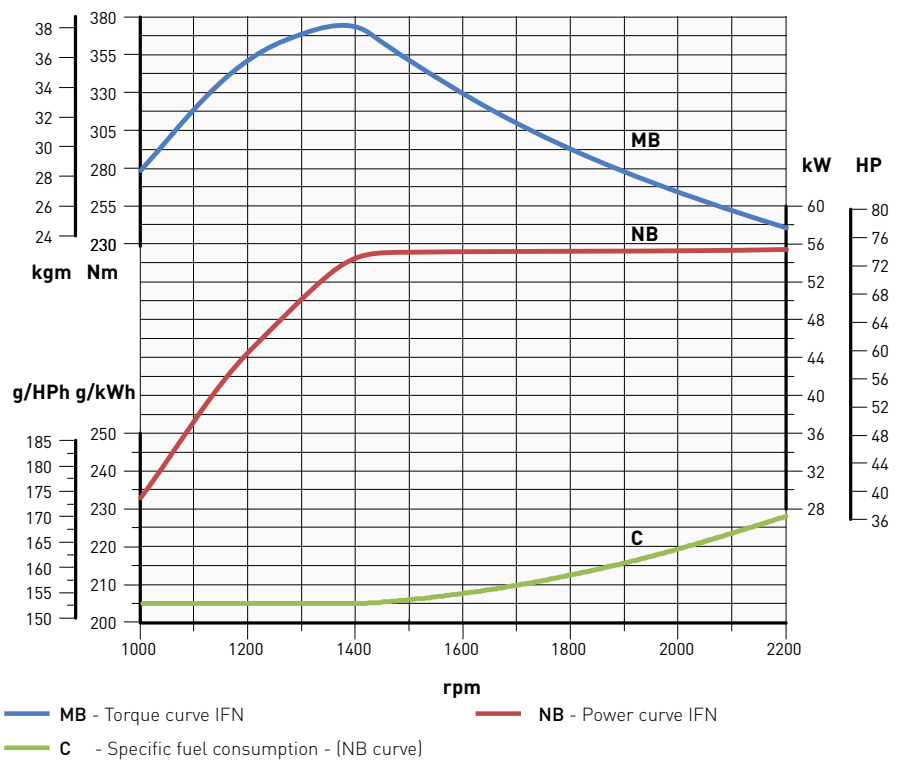

Power ratings refer to engines equipped with air filter, standard muffler, after running-in period at ambient conditions of +25°C, relative humidity 30% and 1 bar. De-rating depending on applications.



KDI 3404TCR SCR

QUICK SPECIFICS

4 Turbo Common rail
CYLINDERS

3359 Displacement
cm³

134 | **100** @ 2200 rpm
HP | **kW** TIER 4 Final
STAGE IV

500 @ 1400 rpm
Nm

DATA

DIMENSIONS (mm)

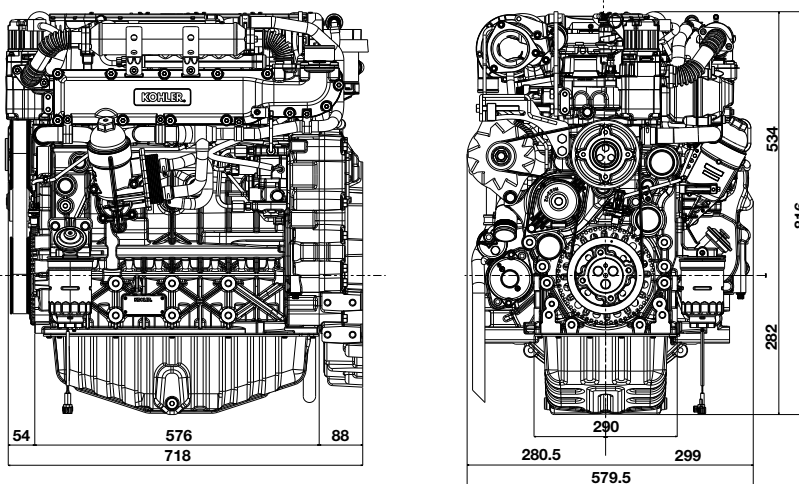

PERFORMANCE CURVES (IFN-ACCORDING TO ISO 3046 AND ISO 14396)

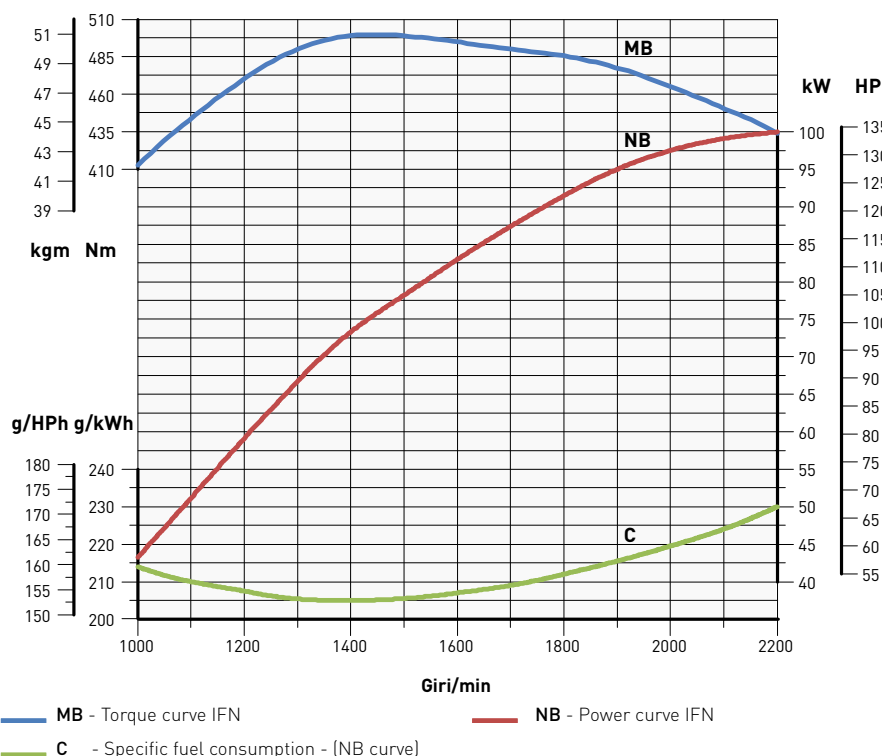

The engine meets US TIER 4 Final / EU STAGE IV emissions standards for power >56 kW thanks to SCR technology (selective catalytic reduction of NOx). The Kohler Engines **SCR** system consists of:

- ECU
- DCU (dosing control unit)
- Supply module
- Heater control valve
- AdBlue pipe
- DOC
- Mixing pipe
- SCR
- NOx and T sensors
- Dosing module

Contact Kohler Engines for dimensions and application information.

Power ratings refer to engines equipped with air filter, standard muffler, after running-in period at ambient conditions of +25°C, relative humidity 30% and 1 bar. De-rating depending on applications.

KDI 3404TCR-SCR

OTHER POWER SETTINGS
AVAILABLE

QUICK SPECIFICS

4 CYLINDERS	Turbo Common rail
3359 cm ³	Displacement
122 90 HP kW	@ 2200 rpm TIER 4 Final STAGE IV
480 Nm	@ 1400 rpm

PERFORMANCE CURVES (IFN-ACCORDING TO ISO 3046 AND ISO 14396)

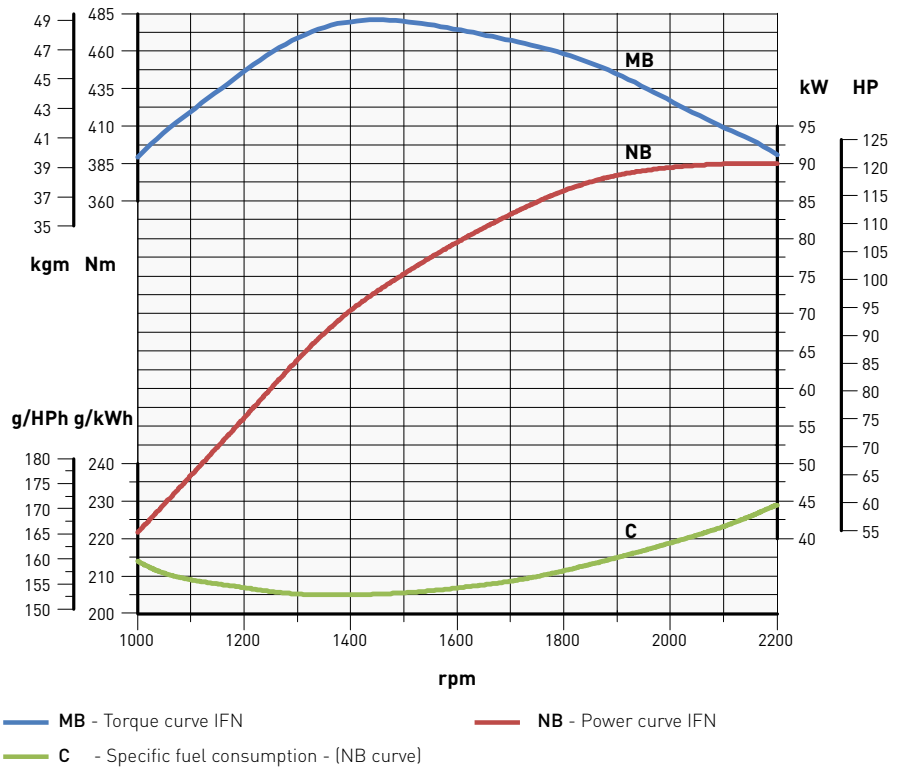

QUICK SPECIFICS

4 CYLINDERS	Turbo Common rail
3359 cm ³	Displacement
102 75 HP kW	@ 2200 rpm TIER 4 Final STAGE IV
475 Nm	@ 1400 rpm

PERFORMANCE CURVES (IFN-ACCORDING TO ISO 3046 AND ISO 14396)

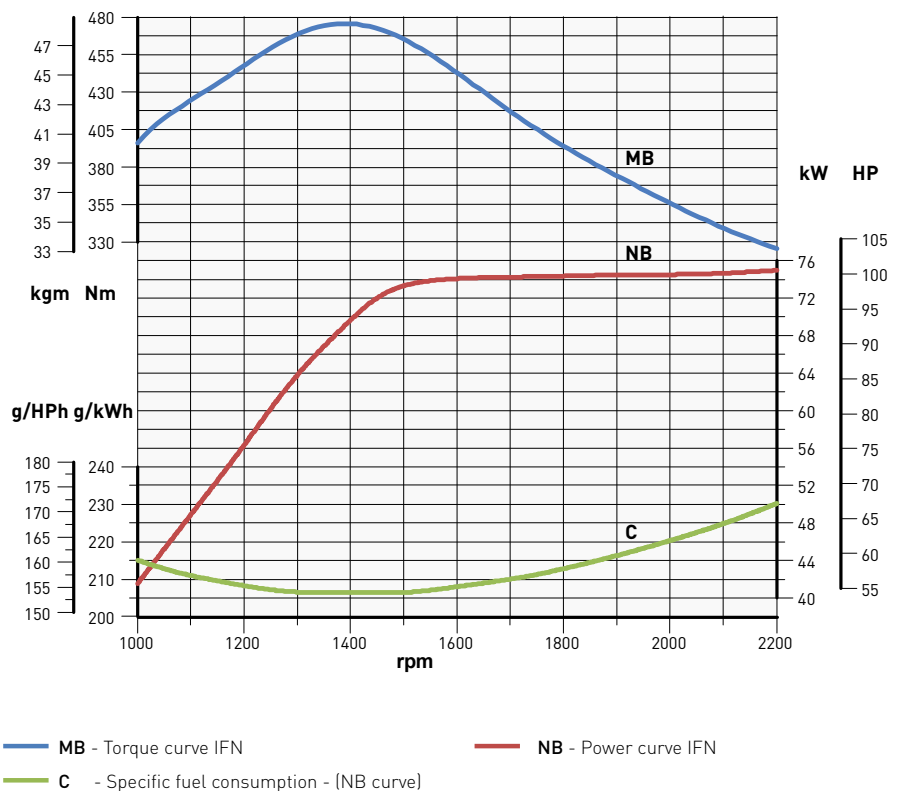

Power ratings refer to engines equipped with air filter, standard muffler, after running-in period at ambient conditions of +25°C, relative humidity 30% and 1 bar. De-rating depending on applications.

TURBO COMMON RAIL ENGINES



Model		KDI3404TCR		KDI3404TCR SCR	
Engine specs	4 stroke diesel with cylinder in line	•		•	
	Liquid cooling	•		•	
	4 valves per cylinder	•		•	
	In crankcase camshaft, gear train driven	•			
	Pushrod - rocker arms timing with hydraulic tappets	•		•	
	Cast iron crankcase with bed-plate	•		•	
	Cast iron cylinder heads	•			
	Closed crankcase ventilation system	•		•	
	High pressure common rail (2000 bar)	•		•	
	Electronic engine management	•		•	
	Waste-gate turbocharger	•		•	
	Charge-air cooling	(•)		(•)	
Technical features	Cylinder	4		4	
	Bore (mm)	96		96	
	Stroke (mm)	116		116	
	Engine displ (cm ³)	3359		3359	
	Injection system	DI		DI	
	Injection Equipment	Common rail (2000 bar)		Common rail (2000 bar)	
Performance	Emission compliance	US TIER 4 Final / EU STAGE III B		US TIER 4 Final / EU STAGE IV	
	Aftertreatment	DOC		DOC + SCR ⁽¹⁾	
	Max power (IFN - ISO 3046 and ISO 14396) (kW@rpm)	55.4 @2200		100@2200	
	Max torque (IFN - ISO 3046 and ISO 14396) (Nm@rpm)	375@1400		500@1400	
	Low-end torque (Nm@1000 rpm)	278		412	
Fuel economy	Best point (g/kWh)	205		205	
	Max power (g/kWh@2400 rpm)	229		230	
	AD-Blue/DEF consumption (%)	-		approx. 4% fuel consumption	
Startability	Unaided (°C)	down to -20		down to -20	
	Aided* (°C) *Manifold grid heater	below -20		below -20	
Fuel compatibility	EN 590	•		•	
	No 1 Diesel (US) - ASTM D 975-09 B - Grade 1-D S 15	•		•	
	No 2 Diesel (US) - ASTM D 975-09 B - Grade 2-D S 15	•		•	
	Arctic EN 590/ASTM D 975-09 B (No petroleum added)	•		•	
Service features	Oil/filter change interval std/synthetic (hr)	500-750*		500-750*	
	Valve adjustment	—		—	
	Alternator belt replacement	36 mth		36 mth	
	Coolant change	24 mth		24mth	
	Oil consumption (% fuel)	<0.1		<0.1	
	* according to operating conditions				
Physical characteristics	H x L x W (fan excluded) (mm)	816 x 718 x 580		816 x 718 x 580	
	Weight (kg)	394		394	
	Daily service points - positions	1 side service		1 side service	
	Ambient operating temps (°C)	-40 to +50		-40 to +50	
	Gradeability-all round (continuous) (deg)	40°		40°	
	Gradeability-all round (intermittent-1min) (deg)	45°		45°	
Cooling & lubrication	Heat rejection to coolant (includes oil cooler) (kW)	45		68	
	Cooling fluid: 50/50 water/antifreeze	•		•	
	Oil type	5W40 low SAPS API CJ-4 ACEA E9 E7 E6		5W40 low SAPS API CJ-4 ACEA E9 E7 E6	
Vibration	Max engine excitation at mounting locations	5g		5g	
Auxiliary PTOs (3rd & 4th) (optional)		3°PTO	4°PTO	3°PTO	4°PTO
	Max torque (Nm)	200	250	200	250
	Drive ratio	1:1.13	1:1	1:1.13	1:1
	Provision for hydraulic pump	SAE A	SAE B	SAE A	SAE B

⁽¹⁾ Model available in all power settings also without after-treatment (SCR) system for markets without emissions requirements.

KOHLER® Engines

Kohler Engines is a brand distributed by Lombardini s.r.l., part of Kohler Group.

Lombardini has manufacturing facilities in Italy, Slovakia and India and sales subsidiaries in France, Germany, UK, Spain and Singapore.

Kohler/Lombardini reserve the right to make modifications without prior notice.

For the latest version please visit our website:

www.lombardini.it

EUROPE

Lombardini Srl

Via Cav. del lavoro
A. Lombardini n° 2
42124 Reggio Emilia, ITALY
T. +39-(0)522-389-1
infodiesel@kohler.com

DEUTSCHLAND

Lombardini Motoren GmbH

Fritz-Klatte-Str. 6, Bürogebäude 2
65933 Frankfurt am Main,
DEUTSCHLAND
T. +49-(0)69-9508160
F. +49-(0)69-95081630

UK

Lombardini U.K. Ltd

1, Rochester Barn - Eynsham Road
OX2 9NH
Oxford, UK
T. +44-(0)1865-863858
F. +44-(0)1865-861754

ESPAÑA

Lombardini ESPAÑA, S.L.

P.I. Cova Solera 1-9
08191 - Rubí (Barcelona)
ESPAÑA
T. +34-(0)9358-62111
F. +34-(0)9369-71613

FRANCE

Lombardini France S.a.s.

47 Allée de Riottier,
69400 Limas, FRANCE
T. +33-(0)474-626500
F. +33-(0)474-623945

ROAPAC

Kohler Singapore Pte Ltd (Kohler Power Systems)

7 Jurong Pier Road
SINGAPORE 619159
T. +65-63020701
Sgsalesall@kohler.com